

Motor Overall Dimension :

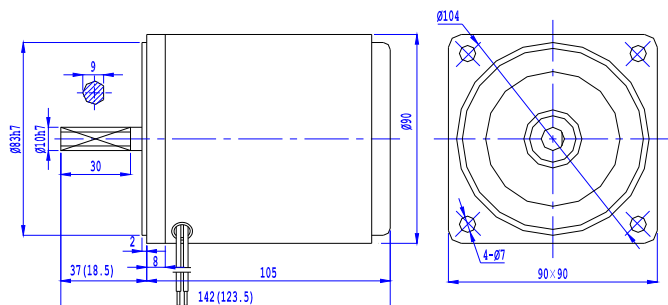

* The value in the () is the value of small gear shaft motor

List of Motor Characteristics

Model of Motor & Gearbox		Output Power (W)	Rated Voltage (V)	Rated Freq'y (Hz)	No. of Poles (P)	Duty Cycle	Rated Load			Starting Torque		Capacitor /Voltage (µF/VAC)	
Motor Only	Motor with Gear Shaft						Speed (r/min)	Current (A)	Torque (N.m)	(kgf.cm)	(N.m)		(kgf.cm)
5IK40A-A	5IK40GN-A	40	1Ph 110	50	4	連続 CONT.	1350	0.64	0.29	2.85	0.25	2.50	10.0/250
5IK40A-C	5IK40GN-C	40	1Ph 220	50	4	連続 CONT.	1350	0.32	0.29	2.85	0.28	2.50	2.5/450
5IK40A-S	5IK40GN-S	40	3Ph 220	50	4	連続 CONT.	1300	0.38	0.29	2.90	1.15	11.5	/
5IK40A-S ₃	5IK40GN-S ₃	40	3Ph 380	50	4	連続 CONT.	1300	0.22	0.29	2.90	1.15	11.5	/
5IK40A-D		40	1Ph 220	50	2	連続 CONT.	2750	0.35	0.15	1.45	0.13	1.25	3.0/450

If the voltage is different, the capacitor's capacity will also be different. A suitable capacitor is required to match the applied voltage. Wrong of the motor or components is the main reason to cause problem. So before order, please specify the correct voltage & select the suitable model(s).

Overall Dimension of Gearbox

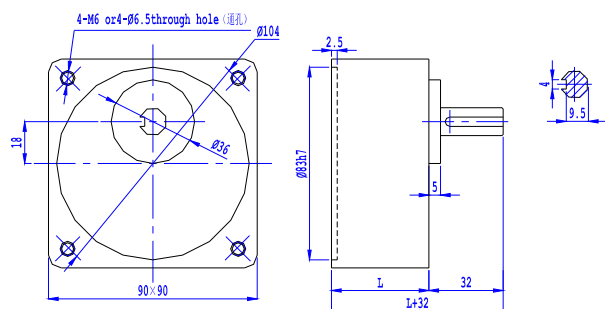

	Gear Ratio	Length L(mm)	G.W. (Kgs)
Gearbox	1:3 ~ 1:18	42	0.73
	1:20 ~ 1:36	60	1.03
	1:40 ~ 1:200		1.13
Motor			2.30

Detailed dimensions of gearbox output spindle

Allowable Torque on Gearbox

Model of Gearbox: 5GN K □

Freq'y	Gear Ratio	Gear Ratio																								
		3	3.6	5	6	7.5	9	10	12.5	15	18	20	25	30	36	40	50	60	75	90	100	120	150	180	200	
50Hz	Output Speed	RPM	500	417	300	250	200	166	150	120	100	83	75	60	50	41	37	30	25	20	16	15	12	10	8	7.5
	Permitted Torque	N.m	0.68	0.82	1.14	1.37	1.72	2.06	2.29	2.86	3.43	4.13	4.59	5.16	6.20	7.44	8.26	9.80	9.80	9.80	9.80	9.80	9.80	9.80	9.80	9.80
	Torque	kgf.cm	6.94	8.37	11.6	14.0	17.6	21.0	23.4	29.2	35.0	42.1	46.8	52.6	63.3	75.9	84.3	100	100	100	100	100	100	100	100	100
60Hz	Output Speed	RPM	600	500	360	300	240	200	180	144	120	100	90	72	60	50	45	36	30	24	20	18	15	12	10	9
	Permitted Torque	N.m	0.58	0.70	0.97	1.16	1.45	1.74	1.93	2.41	2.90	3.48	3.87	4.36	5.23	6.28	6.97	8.72	9.46	9.80	9.80	9.80	9.80	9.80	9.80	9.80
	Torque	kgf.cm	5.92	7.14	9.90	11.8	10.8	17.7	19.7	24.6	29.6	35.5	39.5	44.5	53.4	64.1	71.1	89.0	96.5	100	100	100	100	100	100	100

Capacitor

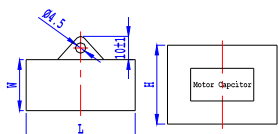

Capacity (µF)	Voltage (V)	L±1 (mm)	W±1 (mm)	H±1 (mm)	Type
2.5	450	37	18	28	With Lead Wire
3.0	450	37	18	28	
10.0	250	47	26	38	

Wiring Diagram

