

Brief Introduction:

1. The rated voltage can be from 100V to 240VAC. The frequency can be either 50Hz, 60Hz, or 50/60Hz.
2. The motor can be made of 2 poles, 4 poles, 6 poles, etc as needed. Single speed, 2 speeds, 3 speeds or 4 speeds are all available.
3. The standard shaft diameter (d) is $\varnothing 6$ or $\varnothing 8$ mm. It can be others, with D-cuts, threads, etc.. Its length (L2) can be any as needed.
4. The stator height (H) can be any from 20mm to 50mm.
5. The bearing brackets (housing) can be made either by steel sheet or by zinc-aluminum alloy, with or without a mounting flange.
6. The rotor bearings can be of either sleeve bearings (bush) or ball bearings as needed to reach different lifetime.
7. The motor rotation can be either in CW or CCW direction as needed.
8. RoHS compliant is available.
9. The motor is CCC certified. **Certificate No.: 2017010401996939.**

Typical Application :

Kitchen Range Hood Fan, Blower, Air Purifier, Ventilator, Clothes Dryer, Air Curtain, etc.

Outline Dimensions (All dimensions in millimeter) :

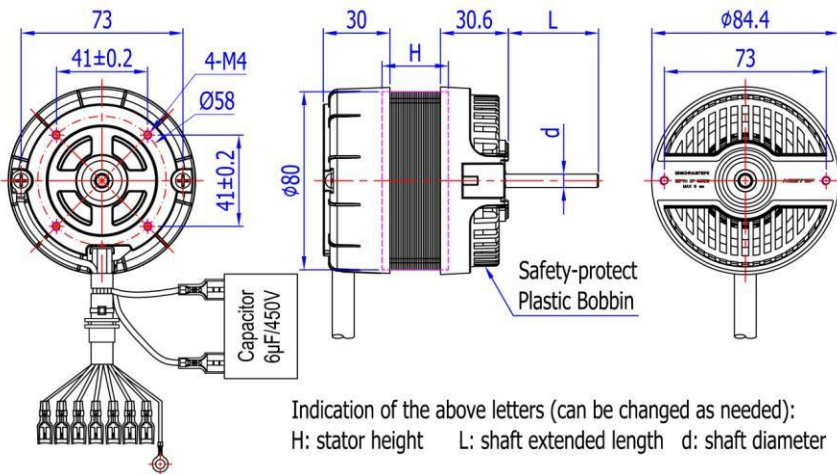

Technical Performances (tested under room temperature):

Specs Model	Stator Height (mm)	Power Supply		Number of Poles	Speed Level	@ No Load		@ Rated Load			
		Volt. (VAC)	Freq. (Hz)			Current (Amp)	Power (Watts)	Current (Amp)	Speed (rpm)	Power (in) (Watts)	Airflow (m ³ /h)
NCP8030	30	220	50	2	F5	0.632	136	0.871	1500	190	431
					F4	0.404	81	0.796	1200	164	385
					F3	0.337	58	0.698	1000	138	332
					F2	0.280	40	0.631	800	120	270
					F1	0.268	37	0.548	600	100	213
NCP8035	35	230	50	2	F3	0.708	119	0.903	2,094	209	756
					F2	0.289	65	0.739	1,399	167	494
					F1	0.203	46	0.620	946	138	327
NCP8040	40	230	50	2	F3	0.356	62	0.910	1720	212	635
					F2	0.198	44	0.785	1281	180	463
					F1	0.126	26	0.578	731	133	274
NCP8050	50	230	50	2	F4	0.670	116	1.341	2074	307	715
					F3	0.350	77	1.072	1650	244	492
					F2	0.260	60	0.835	1320	188	248
					F1	0.120	27	0.330	689	72	150

Remarks: This catalog listed just some typical models. The performances as above are just for reference only. We can adjust our motor specifications according to what the customer needs. OEM & ODM are both welcome.

Brief Introduction:

1. The rated voltage can be from 100V to 240VAC. The frequency can be either 50Hz, or 60Hz, or 50/60Hz.
2. The motor can be made of 2 poles, 4 poles, 6 poles, etc as needed. Single speed, 2 speeds, 3 speeds or 4 speeds are all available.
3. The standard shaft diameter (d) is $\varnothing 6$ or $\varnothing 8$ mm. It can be others, with D-cuts, threads, etc.. Its length (L2) can be any as needed.
4. The stator height (H) can be any from 20mm to 50mm.
5. The bearing brackets (housing) can be made either by steel sheet or by zinc-aluminum alloy, with or without a mounting flange.
6. The rotor bearings can be of either sleeve bearings (bush) or ball bearings as needed to reach different lifetime.
7. The motor rotation can be either in CW or CCW direction as needed.
8. RoHS compliant is available.
9. The motor is CCC certified. **Certificate No.: 2017010401996939.**

Typical Application :

Kitchen Range Hood Fan, Blower, Air Purifier, Juice Extractor, Ventilator, Clothes Dryer, Air Curtain, etc.

Outline Dimensions (All dimensions in millimeter) :

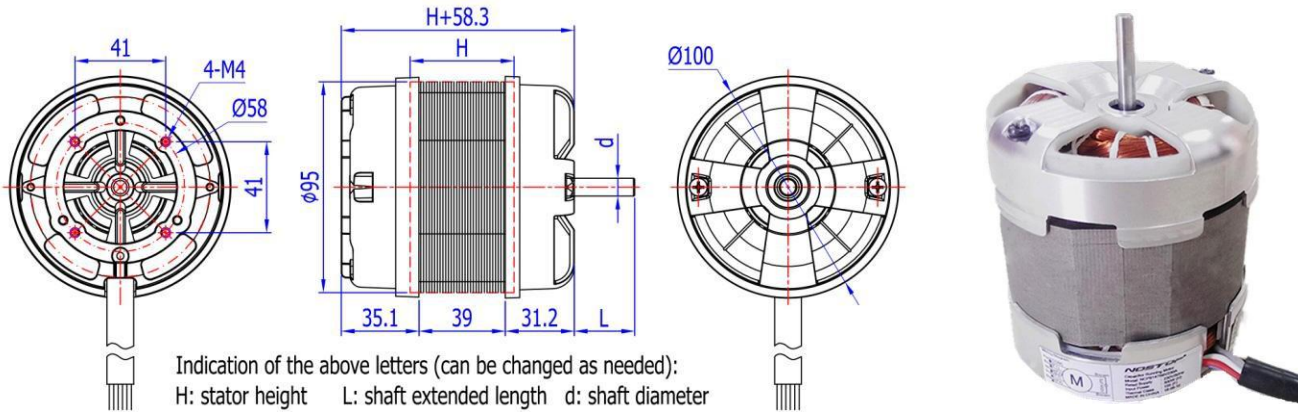

Technical Performances (tested under room temperature):

Specs Model	Stack Height (mm)	Power Supply		Number of Poles	Speed Level	@ No Load		@ Rated Load			
		Volt. (VAC)	Freq. (Hz)			Current (Amp)	Power (Watts)	Current (Amp)	Speed (rpm)	Power (in) (Watts)	Airflow (m ³ /h)
NCP9525	25	220	50	2	F4	0.602	132.0	0.85	1500	185	420
					F3	0.351	70.0	0.72	1100	150	365
					F2	0.298	52.0	0.65	900	132	293
					F1	0.265	43.0	0.59	600	110	220
NCP9535	35	230	50	2	F3	0.361	64.5	0.90	1700	220	640
					F2	0.189	45.6	0.79	1290	185	459
					F1	0.130	28.9	0.61	740	140	270
NCP9547	47	230	50	2	F4	0.294	61.2	1.20	2100	278	729
					F3	0.229	47.5	1.10	1540	254	514
					F2	0.139	27.5	0.60	890	130	297
					F1	0.080	16.8	0.30	671	69	217

Remarks: This catalog listed just some typical models. The performances as above are just for reference only. We can adjust our motor specifications according to what the customer needs. OEM & ODM are both welcome.

Professional Laboratory Equipments

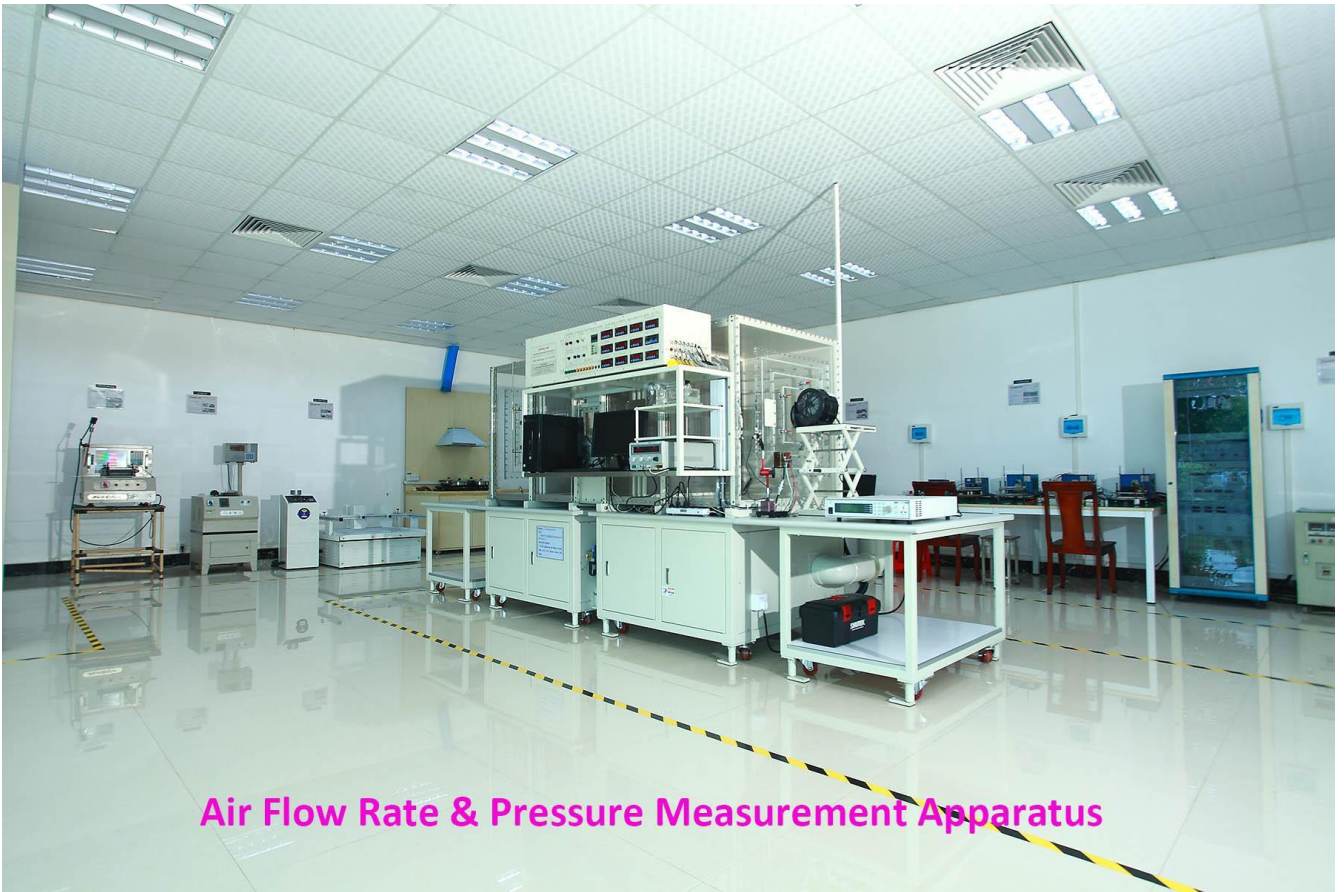

Air Flow Rate & Pressure Measurement Apparatus



Air Flow Rate & Pressure Measurement Apparatus

Professional Laboratory Equipments

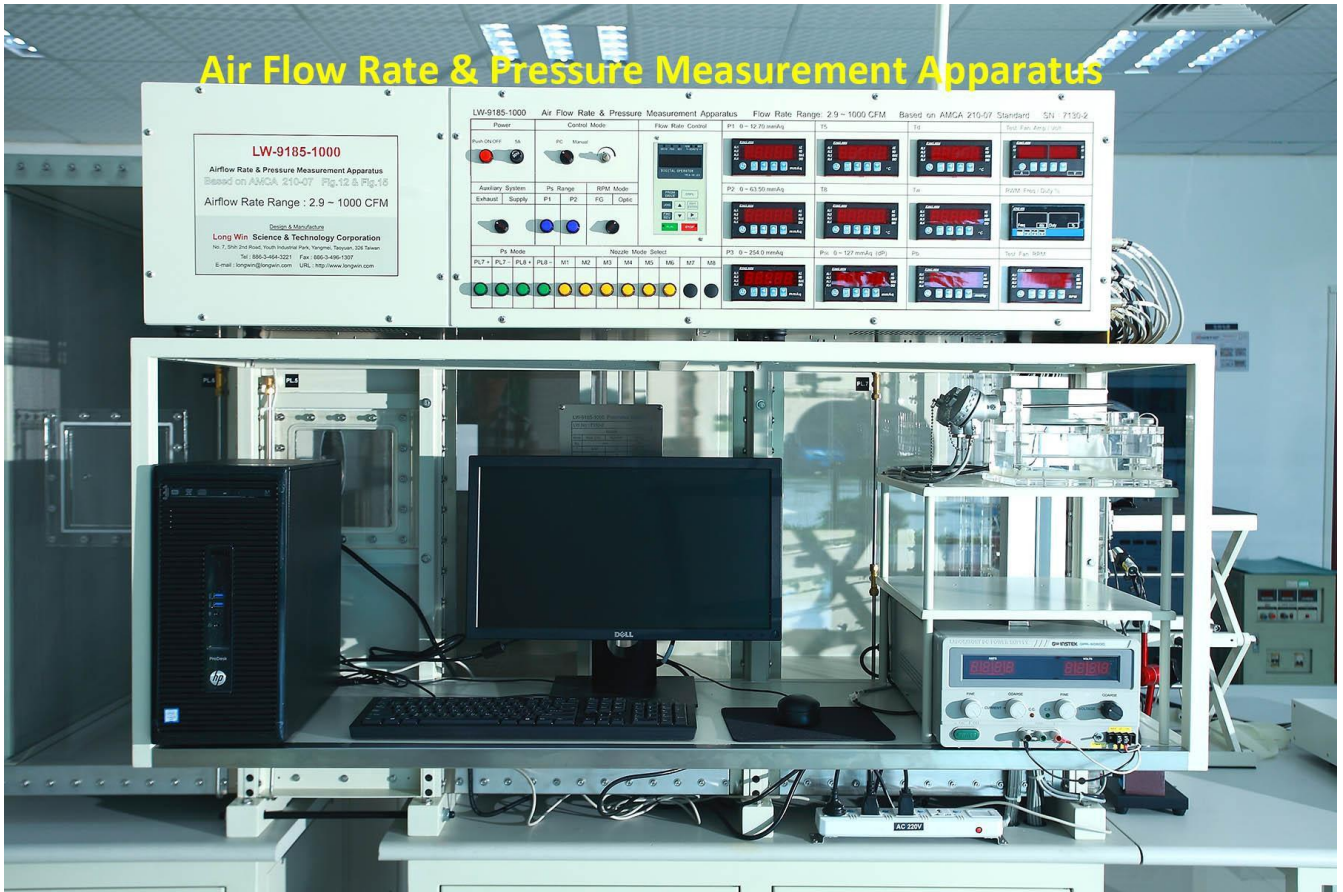

Professional Laboratory Equipments

