

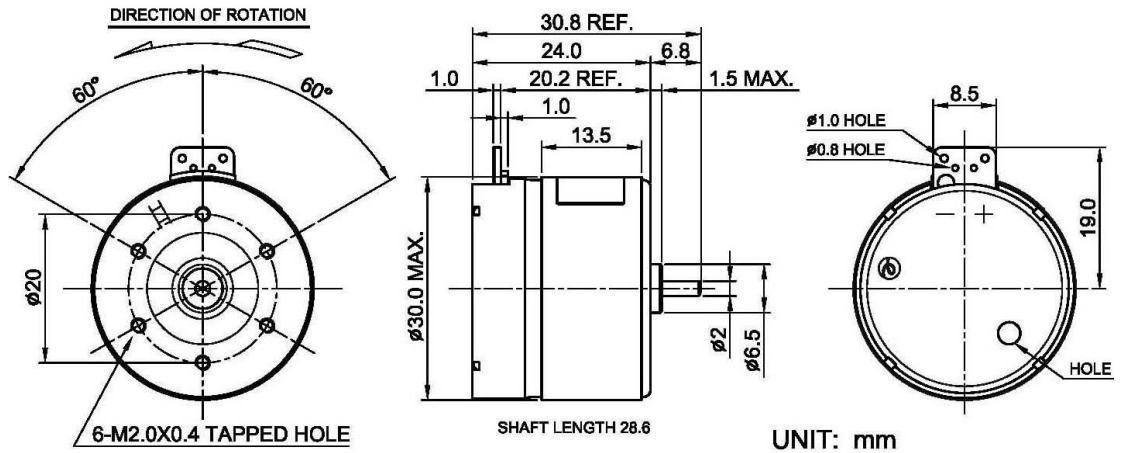

**Typical Application:**

1. Audio and Visual Equipments
2. Car Cassette Tape Recorder

**Weight:** 50g (Approx.)



\* Electronic Governor DC Motor

**ELECTRICAL SPECIFICATION CHART:** (The following specifications can be changed as customers' requirement)

MODEL	RATED VOLTAGE	WORKING VOLTAGE	RATED LOAD		RATED SPEED	RATED LOAD CURRENT	LOAD FLUCTUATION	STARTING TORQUE (MIN)	
	V	V	g·cm	mN·m	rpm	mA (TYP)	rpm/ g·cm (YTP)	g·cm	mN·m
EG520ED-3B	13.2	8.4-16	10	0.98	2400±2%	74	2.5	60at8.4V	5.88at8.4V

**CHARACTERISTIC CURVES:**

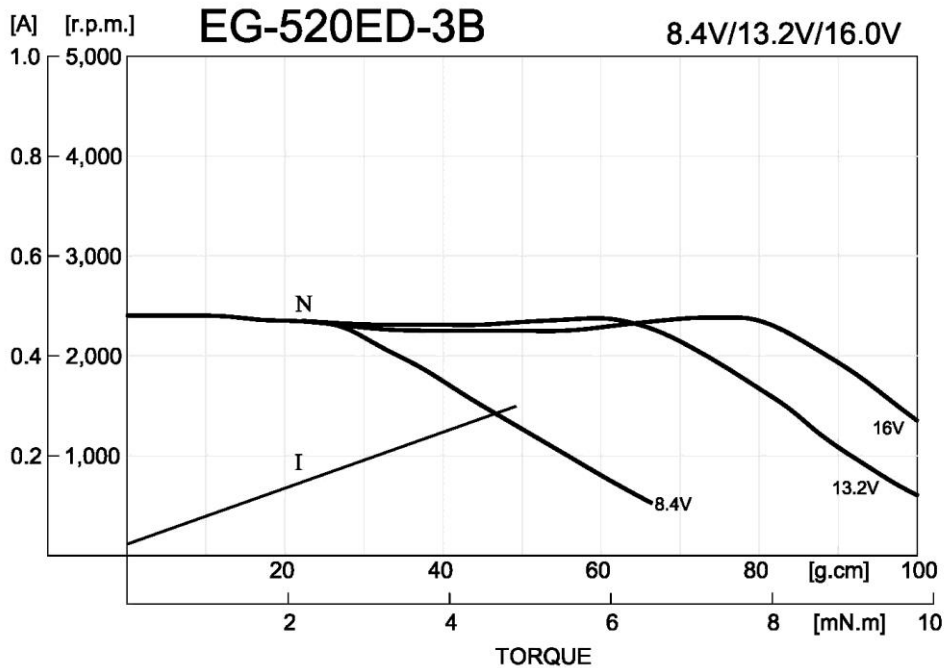

Shenzhen Nostop Electric Co., Ltd

Building C#, Gangzhihong Science & Technology Industrial Park, Qinglong Road, Longhua Town,

Shenzhen City, Guangdong Province, 518107 P.R.China

TEL: +86.755. 2983 4766, 2815 9775, 2815 9776 FAX: +86.755. 2967 4299

E-mail: [stony@nostop.cn](mailto:stony@nostop.cn)

URL: <http://www.nostopmotor.com>, <http://www.nostop.cn>